



**Lotus  
Press  
Milano**

Presse per termostampa e termofissaggio  
Materiali termotrasferibili

*Operating instructions*

*Manual Transfer Press*

**LTS 38**



LOTUS PRESS s.r.l.  
Via Giambellino 14a  
20146 Milan ITALY  
Tel. +39. 02. 48 95 03 86 Fax +39. 02. 48 95 23 55  
info@lotuspress.it / www.lotuspress.it

LOTUS TRANSFER PRESS SOLUTIONS GmbH & Co. KG  
Anklamer Straße 38  
10115 Berlin GERMANY  
Tel. +49. 30. 40 50 45 8 45 Fax +49. 30. 40 50 45 888  
info@lotustransfers.de / www.lotustransfers.de



Thank you very much for buying our Lotus heat transfer press. We are sure you will capitalize on this excellent unit for years if you take the time to read these instructions carefully.

## Introduction

Please study these instructions carefully before transporting, mounting, using or maintaining the transfer press, as they will give you important directions for a safe handling. Moreover, you will find information about how to order spare parts in this manual.

Please retain these instructions for later reference in a safe, easily accessible place.

Please make sure that all operators of the transfer press have understood all instructions and graphic symbols labelled on the press.

Accidents can also be avoided by strictly following the safety regulations according to the machine directive 98/37 CE replaced by 2006/42/CE – 73/23/CE replaced by LVD 2006/95/CE 89/336CE replaced EMC 2004/108/CE. EN 292/1 – EN/292 replaced by UNI EN ISO 12100 and UNI EN ISO 12100-2, EN 60204-1, EMC 2014/30/EU – LVD 2014/35/EU and successive emendations.

It is specifically prohibited to remove or manipulate shrouds or legally compulsory labels or plates.



## Inhalt

Introduction .....	2
Warranty.....	4
Technical Data .....	4
General Safety Instructions.....	5
Intended use and improper use.....	5
Safety instructions.....	5
Danger Warnings .....	6
Environmental conditions.....	6
Installation and transport .....	8
Positioning and electrical connection.....	9
Cap and Plate Set .....	10
Application of the transfer press .....	11
Commissioning of the transfer press .....	12
Parameter adjustment .....	14
Maintenance.....	15
Errors and possible causes.....	16
Disassembly and disposal.....	18
Spare Part's.....	19
Spare Part's - Exploded view.....	20
Heating and pressure plate assembly.....	21
Electric Diagram .....	22



## Warranty

Lotus Press provide you with a 12 months warranty on all their transfer presses (from date of purchase).

To submit a warranty claim is only possible if the transfer press has been mounted and used according to the instructions in this manual and all necessary maintenance has been regularly performed.

During the warranty period defective or broken parts will be repaired free of charge by Lotus Press Milan/Italy.

### **Transport and shipping expenses are on buyer's account.**

The reclaim of defective parts after their replacement is at the discretion of Lotus Press.

Parts needing to be replaced because of maintenance, wear or carelessness are not included in this warranty.

Any claims of consequential costs of a loss or damage, e.g. loss of production, are explicitly excluded from this warranty. No distributor, representative or agent is authorised to assume for Lotus Press any other obligation or liability or to submit a statement different from the one mentioned above.

By accepting this warranty, the customer waives every compensation for losses or damages arising from a production stop.

## Technical Data

<b>Model</b>	<b>LTS 37</b>	<b>LTS 38</b>
Transfer area	40 x 37 cm	38 x 45 cm
Power	2000 W	2000 W
Temperature	0-250°C	0 - 250°C
Timer	0-999 sec	0 - 999 sec
Weight	40 kg	45 kg
Voltage	220 V	220 V



## General Safety Instructions

The safety aspects of the machine have been considered right from the design phase by developing the best solutions for safe use. It should be noted that any modifications made by the user will invalidate the CE declaration of conformity. Furthermore, in this case Lotus Press S.R.L. will no longer be liable for the machine.

The machine is to be connected to a 230 V power supply; this voltage is dangerous when it is contacted. The installation, maintenance and repair work must be carried out by qualified personnel with appropriate knowledge of electrical equipment.

If the mains connection is made by means of an adapter or extension cable, make sure that these are suitable for the power of the machine (2 kW), considering the power of the other consumers connected.

The operator's workplace must be kept in a clean, tidy condition and free from objects that could restrict his freedom of movement.

## Intended use and improper use

The machine has been designed and manufactured exclusively for the application of heat-weldable materials on fabric and other substrates compatible with the operating temperatures.

The good operation and safety of the machine also depend on the place of installation.

It is forbidden to modify or replace any part of the machine without the prior authorization of the manufacturer.

Maintenance and/or repair work must not be carried out until the power plug has been removed from the socket and the heating elements have cooled down to room temperature.

Under no circumstances transfer thermally weldable materials to flammable materials or materials that have encounter solvents, flammable substances, or fuels. The operating temperature could be sufficient to cause a fire.

Do not use the machine in a damp, wet or dusty environment. It is not intended for outdoor use.

## Safety instructions





The press fully complies with the standards. The operations for which the machine is designed can be carried out easily and without risk to the operator.

Compliance with the general safety regulations and the manufacturer's instructions in this manual leaves no room for human error if this is not intentional.

Before starting any work on the press, each user must be familiar with the operation of the machine and its controls and must have read and understood all information contained in this manual.

When using the press, pay attention to the risk of scalding on the heating plate. The main hazards when using the press are listed in the following table:

## Danger Warnings

<i>Symbol</i>	<i>Explanation of Symbol</i>	<b>Safety Measures</b>
	Physical contact with the platen	<p>Switch off the machine and wait 2 hours before changing or touching the platen.</p> <p>Do not check the temperature of the platen with your bare hands.</p> <p>Wear heat-resistant gloves.</p>
	Contact of the platen with flammable materials	<p>Do not heat apply transfers to flammable materials or fabrics that have been in contact with solvents, flammable liquids or combustible liquids or gas.</p> <p>Do not leave flammable or combustible materials near the machine.</p>
 	Closure of the platen	<p>Make sure the power source supplies adequate voltage as listed on the rating plate of the machine.</p> <p>Periodically check the conditions of the power cord and replace it if necessary. Protect the cord and power panel from moisture.</p> <p>Unplug the machine before performing any maintenance.</p> <p>Authorize only expert personnel to work on electrical parts.</p>
	Contact with parts connected to power source	<p>Make sure the power source supplies adequate voltage as listed on the rating plate of the machine.</p> <p>Periodically check the conditions of the power cord and replace it if necessary. Protect the cord and power panel from moisture. Unplug the machine before performing any maintenance.</p> <p>Authorize only expert personnel to work on electrical parts.</p>



## Environmental conditions

To ensure better use of the press, some environmental parameters must be considered:

- A not too humid environment with low air circulation is recommended.
- The optimal environmental conditions of the press operation are:
  - Temperature: 0 - 40°C
  - relative humidity: approx. 60%.

**The manipulation or replacement of parts of the machine is prohibited without the express consent of the manufacturer.**

Any modification of the machine not expressly authorized by Lotus Press will result in civil and criminal liability.

**It is forbidden to remove or manipulate a safety device installed on the machine.**

- **Power supply**

The press is supplied with power, which is supplied via a separable plug and is equipped with an earth connection.

- **Ignition**

The machine is switched on:  
Operation of the main safety switch on the instrument box

- **Maintenance**

"The regulation, maintenance, repair and cleaning procedures are structured in the simplest and safest way. This means that the parts that can be removed cannot be incorrectly or dangerously reset by the operator.

- **Machine identification**

The press is equipped with an identification plate, which serial number and is positioned on the machine body.

	<b>Lotus Press</b>	
Via Giambellino, 14/a - 20146 Milano - Italy		Made in Italy
Tel. +39. 02. 48 95 03 86 - Fax +39. 02. 48 95 23 55		
Modello - Model Modell - Modèle	<input type="text"/>	
Matricola - Serial Number Seriennummer - Matricule n°	<input type="text"/>	
Anno di costru. - Manufac. Year Baujahr - Année der fabrication	<input type="text"/>	
Caratt. elettriche - Electrical Features Elektrische Daten - Caract. électriques	<input type="text"/>	V kW 



## **Installation and transport**

Installation, maintenance, and repair work on electrical equipment must be carried out by qualified and/or competent personnel.

The operator's workplace must be kept clean, tidy, and free from objects that may restrict his freedom of movement.

The instructions, accident prevention regulations and warnings in this manual must always be observed.

Great care must be taken at all stages of transport, positioning and installation of the machine.

### **Packaging and transport**

The Heat press is transported in pallets consisting of wooden and cardboard pallets, in a way that ensures proper transport for the safety and integrity of the machine and its parts.

The press must always be transported in its packaging to avoid uncontrolled movements that could cause damage to the machine and to people or objects.

### **Opening the packaging**

To remove the machine from the packaging:

- 1) Remove the tapes by cutting them with scissors.
- 2) Tear open the sewing clamps
- 3) It is recommended to open the box without damaging it, as it can be reused (transfers, shipments to the manufacturer in case of repair or maintenance).





## Positioning and electrical connection

The transfer press must be installed in a room with an electrical or lighting system approved by the local authorities, and which complies with the applicable electrical safety regulations.

The existing power cable cross-sections must be suitable for the power requirements of the heat press of 2 KW is sufficient, preferably in a separate electric circuit. The characteristic values of the power network must correspond to those of the heat press. Please check the values on the manufacturer's label.

The coloured wire markings of the electrical cables must be carefully must be observed and the transfer press must be earthed. Read in EN 60439 - 1 (CEI 17-13/1) according to. The mains socket outlet must have a protective electrical earthing and a residual current device that switches off at more than 30 mA.

Do not use cables with damaged insulation. Extension cables are not recommended.



## Cap and Plate Set

For this model you may purchase easily interchangeable sets for converting the press:

- a. Cap set with a bent heating plate and bent supporting plate (cf. fig. a)
- b. Plate set (cf. fig. b) consisting of:
  - a supporting plate sized 15 x 38 cm  
e.g. for trouser legs or sleeves and
  - a supporting plate sized 13 x 12 cm  
e.g. for shirt pockets
  - a supporting plate sized 38 x 20 cm  
e.g. for xs-sized lady t-shirts
- c. We'll be happy to produce plates in other sizes for you upon request.

### Inserting and connecting the cap set

To insert the cap set, please pull, with cold and switched off device, the connecting plug from the heating plate to the instrument housing from the socket. Now you can attach the clamping device to the suspension of the heating plate and carefully remove the heating plate and place it safely on a flat surface.

In exchange you can now insert the bent cap heating plate and screw it to the suspension with the clamping device. Now you can connect the plug of this heating element with the socket on the instrument box. The heating element is now ready for use. Now insert the bent cap pressure plate by proceeding as follows.

You can replace the flat pressure plate with the curved cap pressure plate by loosening the locking screw directly below the pressure plate base and lifting it out. Please do not forget to screw the curved Nose Plate after insertion.

#### Tip:

*You can always bring the entire pressure plate into the most suitable position for printing the caps by slightly loosening the locking screw on the device base. You are therefore flexible and can adjust the device to the respective cap head height.*

### Inserting the plate sets

To insert the different pressure plates, loosen the locking screw directly below the pressure plate. Now you can replace the existing pressure plate with the pressure plate of your choice and fix it again with the locking screw.

It is not necessary to replace the heating plate, even if the heating plate is smaller printing plates. However, under no circumstances should you use the curved Use the cap pressure plate together with the flat heating plate for T-shirts.



## **Application of the transfer press**

This transfer press can be used for the transfer of heat-weldable materials to any textile. It may only be operated by one person at a time. The specified maximum temperature should not be exceeded during operation.

Lotus Press cannot be held liable for errors, accidents, damage etc. resulting from failure to follow these operating instructions.

Please note: The use or installation of this transfer press contrary to the instructions given in this instruction manual is strictly prohibited!



## Commissioning of the transfer press

Putting the heat press into operation

Before starting the machine, connect the black power cord to a 220 V power outlet.

Turn on the heat press with the ON/OFF switch on the rear side of the instrument box (on the right side of the instrument) by setting it to I. In the I position, a signal lamp in the switch lights up. The desired working parameters can now be set.

- 1) Set the main switch from 0 to I. As soon as the press is switched on, an acoustic signal is emitted for approx. 1 second and the display shows "888". Immediately afterwards, the actual temperature and the set time are displayed.
- 2) Set the desired temperature.
- 3) Set the desired pressing time.
- 4) Determine the necessary pressure with samples.

To regulate the pressure, turn the pressure regulator (hand screw immediately behind the hand lever) in the appropriate direction:

- clockwise, to reduce the pressure
- counterclockwise, to increase the pressure

Please adjust the pressure only when the heating plate is open, otherwise the printing column may be damaged!

Place the textile to be printed on the lower printing plate and place the transfer to be processed on it.

To start the transfer process, pull down the hand lever. As a result, the heating plate is pressed onto the printing plate and the transfer process is started.

After the preset time for the process has elapsed, the hand lever must be pushed up again manually to end the pressing process.

Pay attention to the temperature and the transfer time and follow the instructions of the manufacturer of the material you want to transfer.

General programming of the TS2 900 control board:

When the power supply is switched on, the buzzer of the board sounds for about one second and both displays show the number "888" (functional diagnostics), then for about one second the number 900, which refers to the program number, and immediately afterwards the temperature detected by the probe and the set cycle time.

To set your parameters, proceed as follows:

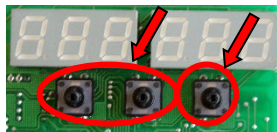
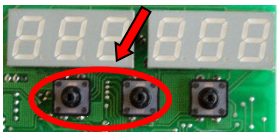
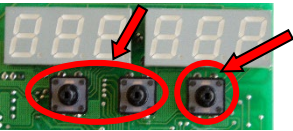
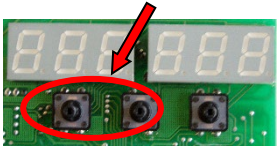
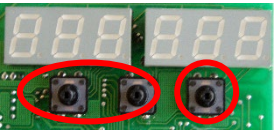
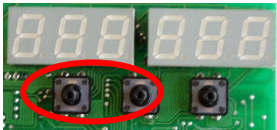
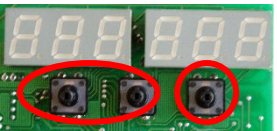
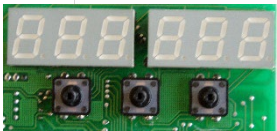
<p><b>1</b> Once you press the S button, the left display displays the default temperature.</p> 	<p><b>2</b> To change the working temperature, use the left buttons (+ / -).</p> 
<p><b>3</b> If you press the S button a second time, the left display displays the cycle time.</p> 	<p><b>4</b> To change the cycle time, press the left (+/-) buttons.</p> 
<p><b>5</b> COUNTING OF PRESS PROCESSES By pressing the S button a third time, the left display shows the number of press processes since turning on the press.</p> 	<p><b>6</b> BACKING OF THE COUNTER Press the (+/-) buttons together. The counter on the on the left/right display is reset to zero.</p> 
<p><b>7</b> READOUT THE ENTIRE PRESSING OPERATIONS By pressing the S button a 4th time, the left display shows the total number of pressing operations</p> 	<p><b>8</b> RESETTING ALL PRESS OPERATIONS Press the (+/-) buttons together. The counter on the on the left/right display is reset to zero.</p>  <p>The TS2 900 control board is programmed in this way, that the set values are saved two seconds after the end of the input.</p>



## Parameter adjustment

### Standardprogramm (00)

Please press button **S** for 25 seconds. The display confirms access to the programm by showing up **00** followed by flashing and an audible signal.

To choose programs 01, **02 and 03** please press button **S** again.

### Flex-Programm (01)

8. Press button **S**
9. The display shows up **01**, followed by the audible signal and blinking
10. On the display the preset parameters appear: **160°C** and **15** seconds

### Flock-Programm (02)

- Press button **S**
- The display shows up **02**, followed by the audible signal and blinking
- On the display the preset parameters appear: **150°C** and **15** seconds

### Sublimationsprogramm (03)

- Press button **S**
- The display shows up **03**, followed by the audible signal and blinking
- On the display the pre-set parameters appear **200°C** and **60** seconds

The operator may change the preset parameters with buttons „+“ and „-“. The modified parameters may be saved directly by pressing button **S** and may always be recalled and altered again.

The preset temperature may be modified in each programm (01...02...03) plus or minus 20 °C. For the standard programm however, temperatures between 0°C and 250° may be adjusted.

### Display signals

In case of failures, the new control board **TS2 3P** gives different signals to discover and resolve the problem immediately.

- If **111** appears on the display and the light blinks, followed by an acoustic signal, the temperature sensor is defect or not connected with the control board.
- If **000** appears on the display and the light blinks, followed by an acoustic signal, the temperature ranges about 15°C because of a default. The control board must be checked.



## Maintenance

Please read the instructions in this manual carefully before starting any maintenance or repair work.

Maintenance and repairs must be carried out by an authorised service centre and/or specialised personnel using only original spare parts.

Actions that do not comply with the following safety instructions may cause serious injury to the user and/or damage to the transfer press cause.

Before carrying out maintenance work, the transfer press must be switched off and the plug must be removed from the mains socket.

Please note the high temperatures of the upper heating plate. It can take up to 20 minutes to cool this plate to below 50°C.

Before switching the appliance back on (on) after maintenance or cleaning, make sure that no tools or spare parts are left in or on the appliance and that safety devices, graphic symbols and instructions on the heat press are in good condition and legible.

All maintenance and repair work may only be carried out when the press is disconnected from the electrical and pneumatic mains.

Behaviour that does not comply with the safety regulations can lead to personal injury and/or damage to the machine.

Also check that all safety devices are present and functional

### REPLACING THE RESISTOR AND THERMOCOUPLE

After electrically isolating the press by removing the plug from the power outlet, disconnect the wire harness plug from the instrument box, then disconnect the resistor and/or thermocouple wires from the wire harness plug.

Remove the upper heater plate cover, this allows access to the thermocouple and resistor. Proceed with the replacement, making sure that the original connections are restored. Refer to the attached wiring diagram to reconnect the correct connections.

Use only original LOTUS resistors and thermocouples.

### REPLACING THE FUSE

To change the fuse it is necessary to open the instrument box, after the press has been insulated by removing the plug from the socket, the fuse is placed in the instrument box.

Make sure that the fuse is replaced with one with the same characteristics (voltage and Am-pere).



## Errors and possible causes

ERROR MESSAGE	POSSIBLE CAUSE	TROUBLESHOOTING
The main switch is not lit	<ul style="list-style-type: none"> <li>- Lamp defective</li> <li>- Power cable defective</li> </ul>	Replace the part
The heating plate does not go down	<ul style="list-style-type: none"> <li>- Control board defective</li> <li>- Electric valve defective</li> <li>- Start-Knop defective</li> <li>- Hands safety system defect</li> </ul>	Replace the part
The heating plate moves down independently	No pneumatic connection available (machine does not get air supply)	Checking the air system
The display shows "000" and there is an acoustic signal	<ul style="list-style-type: none"> <li>- Control board defective</li> <li>- The temperature is 20°C above the set temperature</li> </ul>	Replace the part
The display shows "111"	Temperature sensor defective	Replace the part
The display does not count the seconds, the heating plate does not stay down	Pressure regulator defective	Clean or replace the pressure regulator
The heating plate does not heat up	<ul style="list-style-type: none"> <li>- Wiring heating plate defective</li> <li>- Heating rod/heating rods defective</li> </ul>	Replace the part
Air escapes from the pressure filter (on the back of the press)	<ul style="list-style-type: none"> <li>- Electric valve defective</li> <li>- Pressure cylinder defective</li> </ul>	Replace the part
The printing cylinder moves slowly downwards	The pressure regulator is clogged	Clean the pressure regulator or replace the part
Display is not lit	<ul style="list-style-type: none"> <li>- Control board defective</li> <li>- Power cord defective</li> <li>- Fuse defective</li> </ul>	Replace the part





<b>ERROR MESSAGE</b>	<b>POSSIBLE CAUSE</b>	<b>TROUBLESHOOTING</b>
Short circuit	Heating element defective	Replace the part
The press does not react after switching on	<ul style="list-style-type: none"><li>- The plug is not inserted correctly</li><li>- There is no electrical connection</li><li>- Fuse defective</li></ul>	<ul style="list-style-type: none"><li>- Plug properly plugged in</li><li>- Check the power line</li><li>- Replace the part</li></ul>
The heating plate is not parallel to the printing plate	The quick release has moved	Adjusting the quick release



## Disassembly and disposal

If the machine must be disposed of, disassemble it according to the applicable regulations and dispose of the individual parts separately. The replaced parts must not be dispersed in the environment but must be disposed of in accordance with the laws in force in the country where the machine is used. The machine consists mainly of the components steel, rock wool, Aluminium, and plastic.

The user must deliver the waste to the Centres for separate waste disposal or handed over to the dealer when purchasing a new appliance of the same type.

In Italy, unauthorised disposal by the user is punishable by the administrative penalties described in art. 255 and subsequent of Legislative Decree no. 152/06.

### INFORMATION TO USERS

Within the meaning of Article 13 of Legislative Decree of 25 July 2005, No 151 "Implementation of Directives 2002/95/CE, 2002/96/CE, and 2003/108/CE, in connection with Reduction of the use of hazardous substances in electrical and electronic equipment and with waste disposal". The symbol with the crossed-out dustbin attached to the device or on the packaging indicates that the product must be disposed of separately from other waste at the end of its service life.

The separate collection of this obsolete device is organised and managed by the manufacturer. The user who wishes to dispose of it must contact the manufacturer and follow the system used by the manufacturer for separate waste disposal.

Appropriate separate waste management and recycling of the end-of-life appliance, environmentally sound treatment and disposal will help to prevent possible negative effects on the environment and health and will promote the re-use and/or recycling of the appliance's components. Unauthorised disposal by the user will result in the application of the administrative penalties provided for by the applicable laws.



## Spare Part's

38001	Basement
38002	Arm right
38002 A	Arm left
38003	Lever
38004	Coupling rod
38004 A	Pole
38005	Screw for pressure regulation
38006	Hand grip
38007	Tension spring
38008	Tension spring bold
38009	Rear cover
38010	Screw nut
38011	Screw for fastening the tension spring
38012	Lever pin
38013	Spacer Ø 12 x 2 pcs.
38014	Kuppelstangenstift
38015	Spacer Ø 16 x 2 pcs.
38016	Lever pin
38017	Instrument box
38018	Box cover
38019	Cable press
38020	Display stickers
38021	Control Board S1
38022	Switch
38023	Cover (4 pcs.)
38024	Feet (4 pcs.)
38025	Spacer of the arm
38026	Quick release
38027	Hand grip for fixing the printing plate
38028	Support of the printing plate
38029	Teflon cover
38030	Teflon tension spring
38031	Teflon bar
38032	Hanger (left and right)
38033	Cover of the heating rods
38034	Cover of the heating plate
38035	Heating rods
38036	Heating plate
38037	Temperature sensor
38038	Silicone rubber
38039	Pressure plate



## Spare Part's - Exploded view

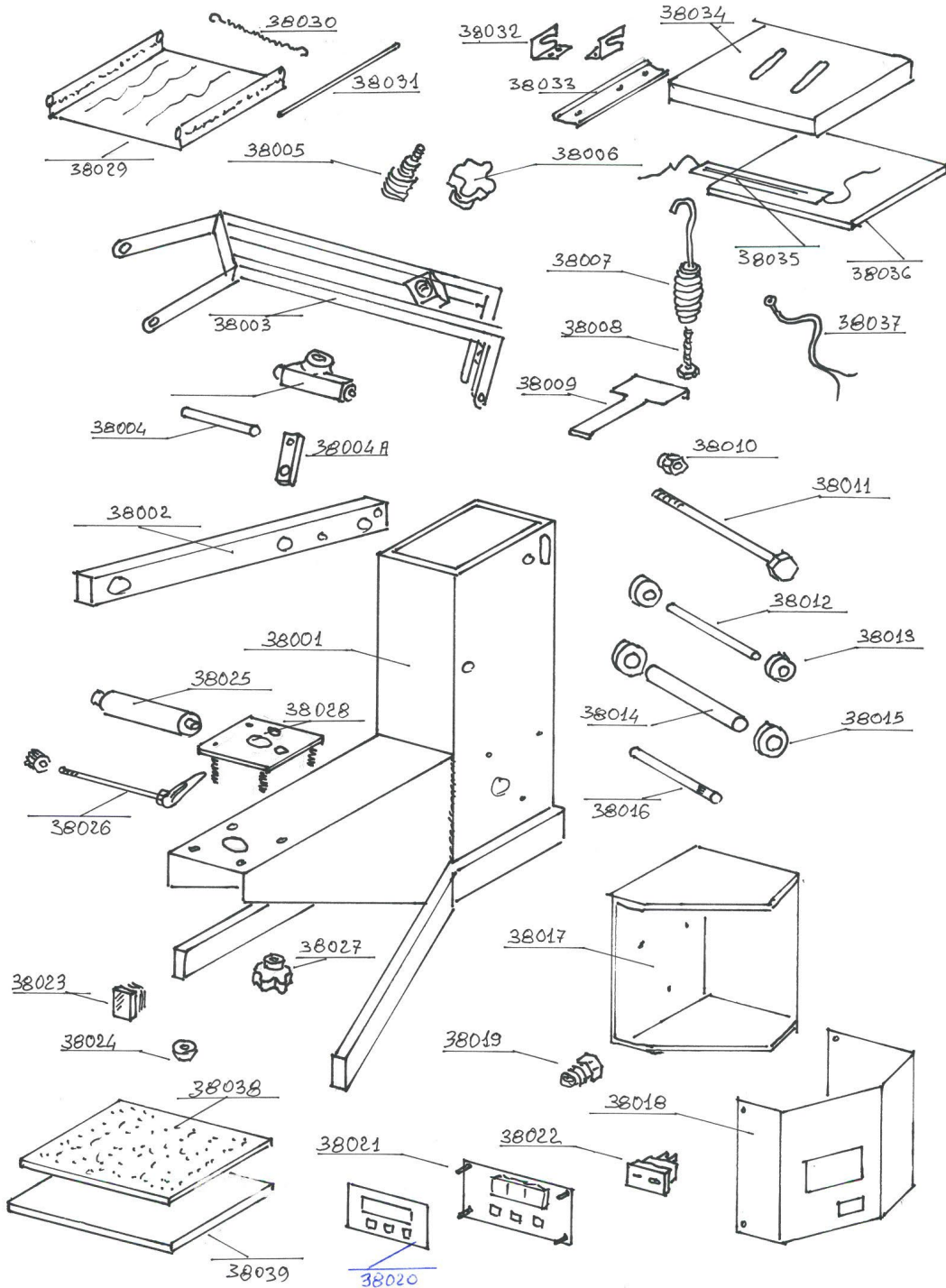



## Heating and pressure plate assembly

with Mikanit heating technology

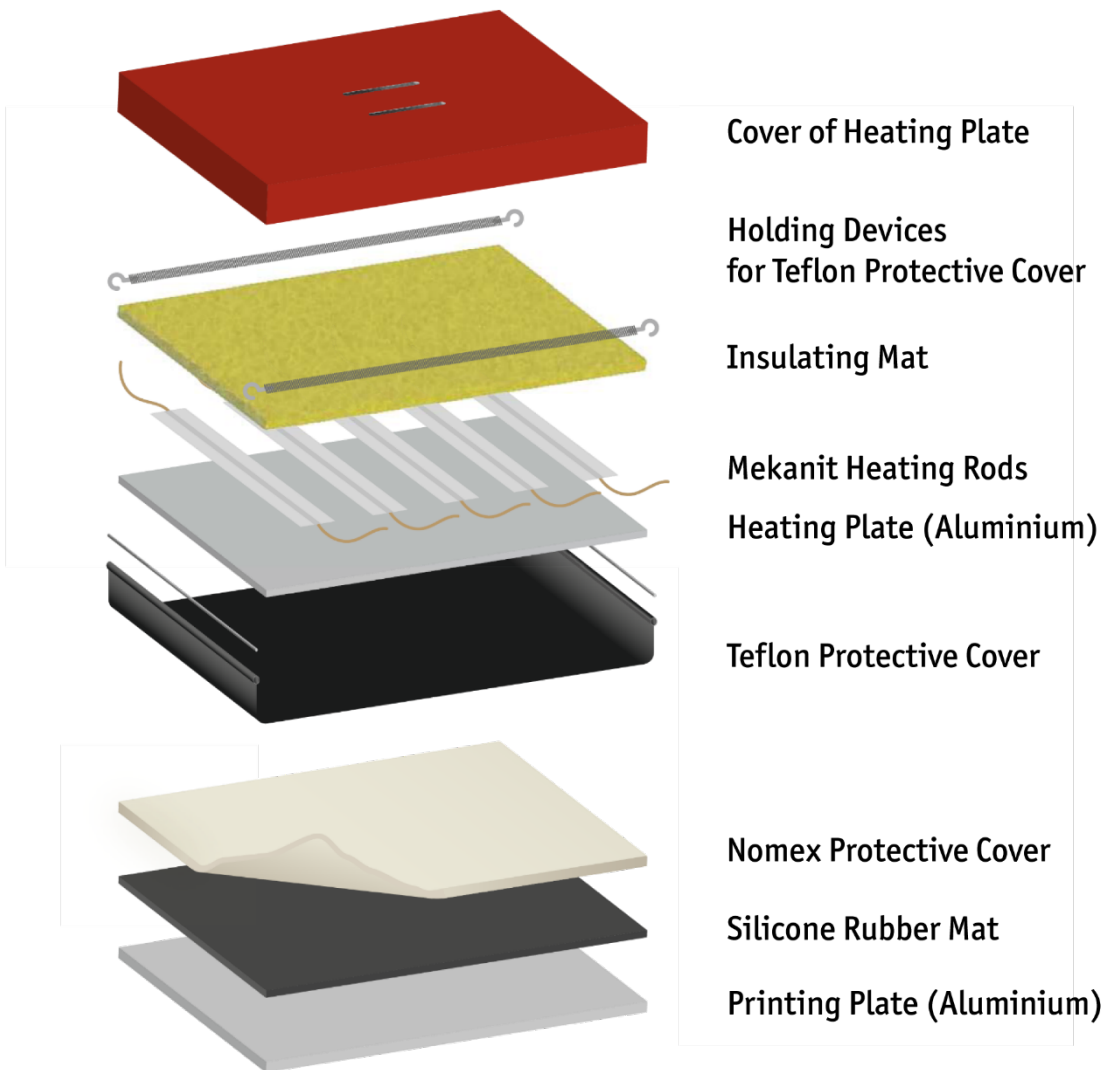



# Electric Diagram

